



PIATTAFORMA PER LAVORO AEREO AUTOCARRATA

TRUCK-MOUNTED AERIAL LIFT WORK PLATFORM

HUBARBEITSBÜHNE AUF LKW

NACELLE ÉLEVATRICE ARTICULÉE

F.I.M. NOLEGGI



PNT220NLX

isoli@isoli.com | www.isoli.com



DIMENSIONI / OVERALL DIMENSION / GESAMTABMESSUNGEN / DIMENSIONS [mm]



DIAGRAMMA DI LAVORO / WORKING DIAGRAM / ARBEITSDIAGRAMM / SCHÉMA DE TRAVAIL [m]

A= 80kg B= 120kg C= 200kg D= 250kg

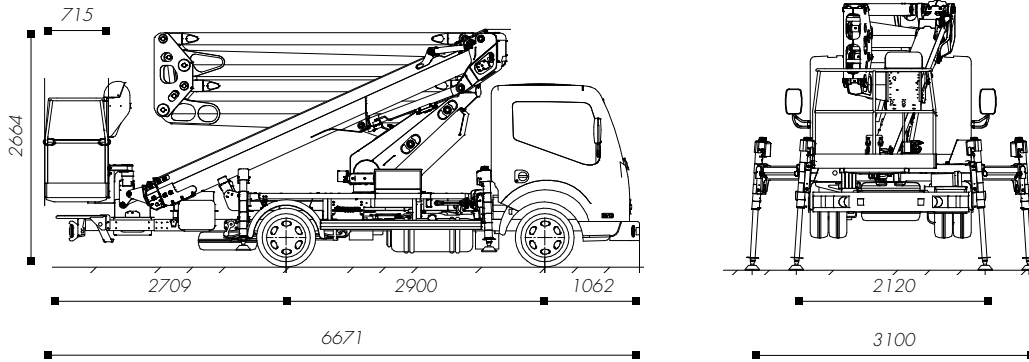
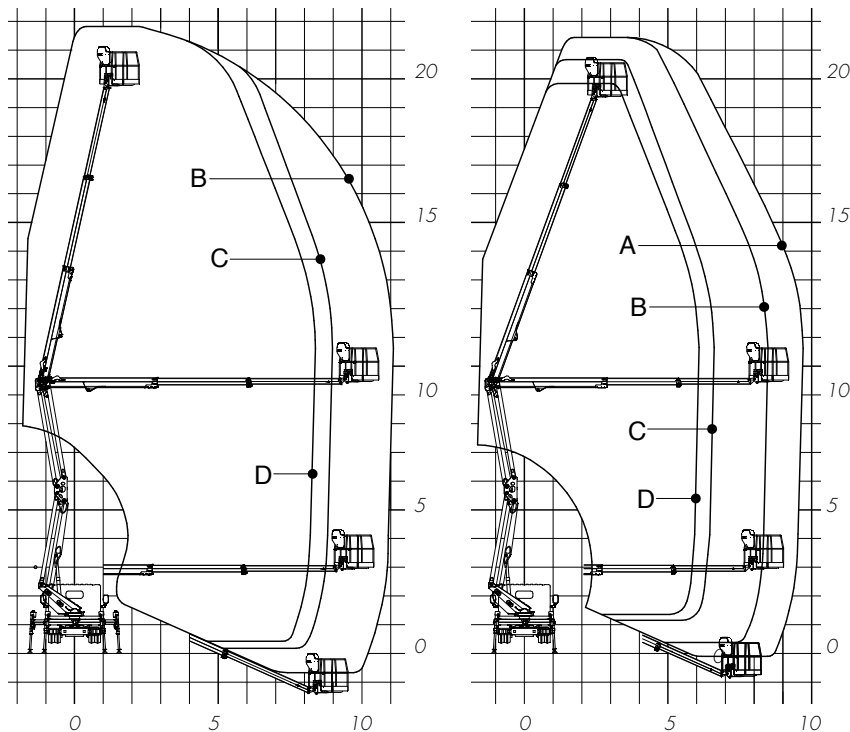

CARATTERISTICHE TECNICHE / TECHNICAL FEATURES / TECHNISCHE EIGENSCHAFTEN / DETAILS TECHNIQUES

	Altezza max. di lavoro Max. working height Max. Arbeitshöhe Hauteur travail	21,8 m
	Sbraccio max. di lavoro Max. working boom extension Max. Reichweite Portée à hauteur maximale	11,2 m
	Portata Capacity Traglast Charge utile	250 Kg
	N. operatori N. operators Anzahl Personen N. opérateurs	2
	Altezza piano calpestio Walk-on surface height Korbodenhöhe Hauteur plancher	19,90 m
	Rotazione sovrastruttura Upperstructure rotation Drehung Oberwagen Rotation tourelle	60°
	Cesta Basket Arbeitskorb Panier	Aluminium 1400x710x1115 mm Aluminium 1400x710x1115 mm Aluminium 1400x710x1115 mm
	Rotazione cestello Basket rotation Korbrotation Rotation panier	90° dx/sx 90° R.-H./L.-H. 90° Rechts/Links 90° droite/gauche
	Comandi Controls Steuerungen Commandes	Elettroidraulici Electro-hydraulic with can bus control panel Elektrohydraulische CAN-Bus-Steuerungen Électrohydrauliques avec tableau de commande CAN-Bus
	Stabilizzatori Outriggers Abstützungen Stabilisation	H-H